



DORADO EVO

SEEDING MONITOR FOR PLANTERS



NO. 2202-EN
Rev.2

USER'S MANUAL





This product complies with EMC standards as determined in 2004/108/EC directive and subsequent amendments, as referenced in the applied EN ISO 14982 standard

Manufacturer : MC elettronica S.r.l.
Address : Via E. Fermi, 450/486
Fiesso Umbertiano (ROVIGO) - ITALY
Tel. +39 0425 754713
E-mail: info@mcelettronica.it
Internet: www.mcelettronica.it

Manual p/n : **2202-EN**
Issued : August 2023
Edition : August 2023

MC elettronica S.r.l. is not obliged to give notice of any further modifications of the product.

The information given in this manual does not allow unauthorised personnel to tamper with the product in any way.

The warranty of the equipment will no longer be valid if tampering occurs.

© Copyright MC elettronica 2023

Contents

1. General warnings	5
1.1 Introduction	5
2. General description	6
3. Sensors installation	7
3.1 Speed sensor installation	7
3.2 Work sensor installation	8
3.3 Photocells installation and wiring	9
3.4 Flowmeter installation (optional)	11
3.5 Fan speed sensor installation (optional).....	12
4. Operation	13
4.1 Splash screen	13
4.2 Main screen	14
4.2.1 Seeding quality area	16
4.2.1.1 Histograms.....	17
4.2.1.2 Tables display.....	18
4.3 Menu	20
4.3.1 User settings	21
4.3.1.1 Seed menu	21
4.3.1.2 Sensor menu	23
4.3.1.2.1 Speed sensor	24
4.3.1.2.2 Work sensor	26
4.3.1.2.3 Vacuum sensor	27
4.3.1.2.4 RPM sensor	28
4.3.1.2.5 Flow sensor	29
4.3.1.3 Geometry	30
4.3.1.4 Counters	30
4.3.2 Machine settings	33
4.3.2.1 Photocell	34
4.3.2.2 Alarm settings	35
4.3.2.3 Total counters	35
4.3.2.4 Reset to default ?	36
4.3.3 Diagnostics menu	36
4.3.3.1 ECU	37
4.3.3.2 Seeding statistics	39
4.3.3.3 User manual	40
4.3.4 VT settings	40
4.4 Alarms.....	41
4.5 Update	42

1. General warnings

1.1 Introduction

This instruction manual provides all specific information needed to know and correctly use the equipment.

After buying the Monitor, read the manual carefully and refer to it any time you have doubts about how to use the equipment, or when you need to carry out maintenance operations.

This manual shall be kept for reference inside the machine or in a known, easy accessible place.

ALL RIGHTS RESERVED. THIS MANUAL IS INTENDED FOR CUSTOMERS ONLY. ANY OTHER USE IS FORBIDDEN.

2. General description

The *DORADO EVO* is a multifunctional monitor designed for pneumatic or mechanical precision planters. The device can monitor up to 12 rows with digital photocells, or up to 48 rows with LIN photocells.

The monitor can accurately monitor the sowing distance of single rows and the amount of seeds applied per square meter.

It also checks the correct seeding on each row, signalling acoustically and visually any eventual sowing anomaly.

During work, the following data can be checked:

- vehicle speed in kilometres per hour (Km/h) or miles per hour (mph)
- vacuum level of the seeding unit (-mBar) or inches of mercury (inHg)
- rev speed of fan (RPM)
- weed killer dose distributed per minute (litres/min)
- weed killer dose distributed per hectare (litres/ha) or gallons per acre (gal/ac)
- counter of litres of weed killer distributed (litres)
- partial area worked in hectares (ha) or acres (ac)
- partial counter of working time (h)
- linear distance covered in metres (m) or feet (ft)
- instantaneous productivity in hectares per hour (ha/h) or acres per hour (ac/h)
- sowing distance in centimetres (cm) or inches (in)
- population of seeds per square metre (seed/m²) or per square foot (seed/ft²)

The monitor carries out the above-mentioned operations by means of photocells, installed on each single row of the planter, a speed sensor and a work sensor.

In the case of sowing with simultaneous weed killer distribution, install an optional flowmeter sensor. If programmed appropriately, the monitor can trigger acoustic and visual alarms, in case the weed killer distribution is erratic.

3. Sensors installation

The *DORADO EVO* Monitor can be equipped with 3 types of sensors:

- Speed inductive sensor (mandatory) like p/n 2573_KS, etc;
- work sensor (mandatory) p/n 1414_KS;
- photocells (mandatory) like p/n 10FOT-0065 (UniSeeder w/ pipe), 10FOT-0092 (MaxiSeeder w/pipe), etc;
- Fan speed sensor (optional) like p/n 2573_KS, etc;
- flowmeter sensor (optional) p/n 952, 598;
- Vacuum gauge sensor (optional, not supplied by MC elettronica).

3.1 Speed sensor installation

You can install the speed sensor (p/n 2573) anywhere there is mechanical movement, e.g. the rim of a front or rear wheel of the planter, or applying any metal reference like a bolt, protruding by at least 7 mm from its backplane (Figure 1 - ref. <C>). We recommend installing the speed sensor inside the wheel and placing the sensor head opposite the rim bolts (Figure 1 – ref. <A>).

Set the gap between the sensor and the bolts at about 2÷3 mm (Figure 1 – ref.). Securely bolt the sensor's bracket (supplied) to a fixed part of the planter's chassis. Fix the sensor to its bracket with the hex nuts and tighten them.



Warning
The sensor cable should be covered with a rubber sheath.

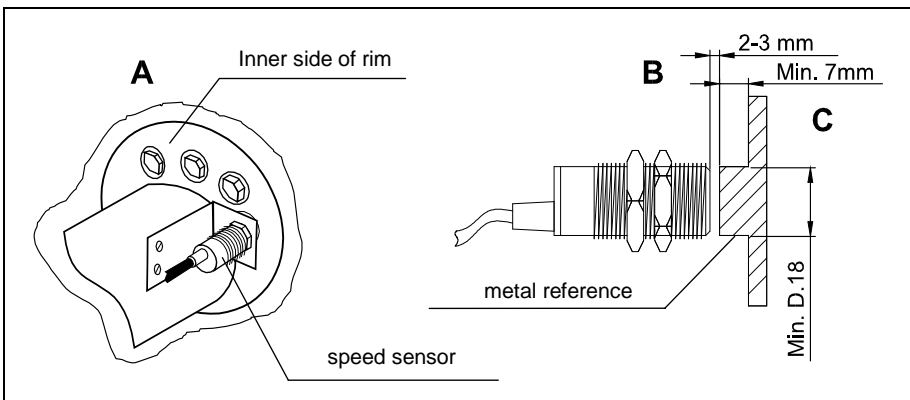

Figure 1. Installing the speed sensor p/n 2573.

3.2 Work sensor installation

The work sensor is used to detect when the planter is lowered to the ground. It works like a simple switch (closed when folded).

The following figures show an installation example.

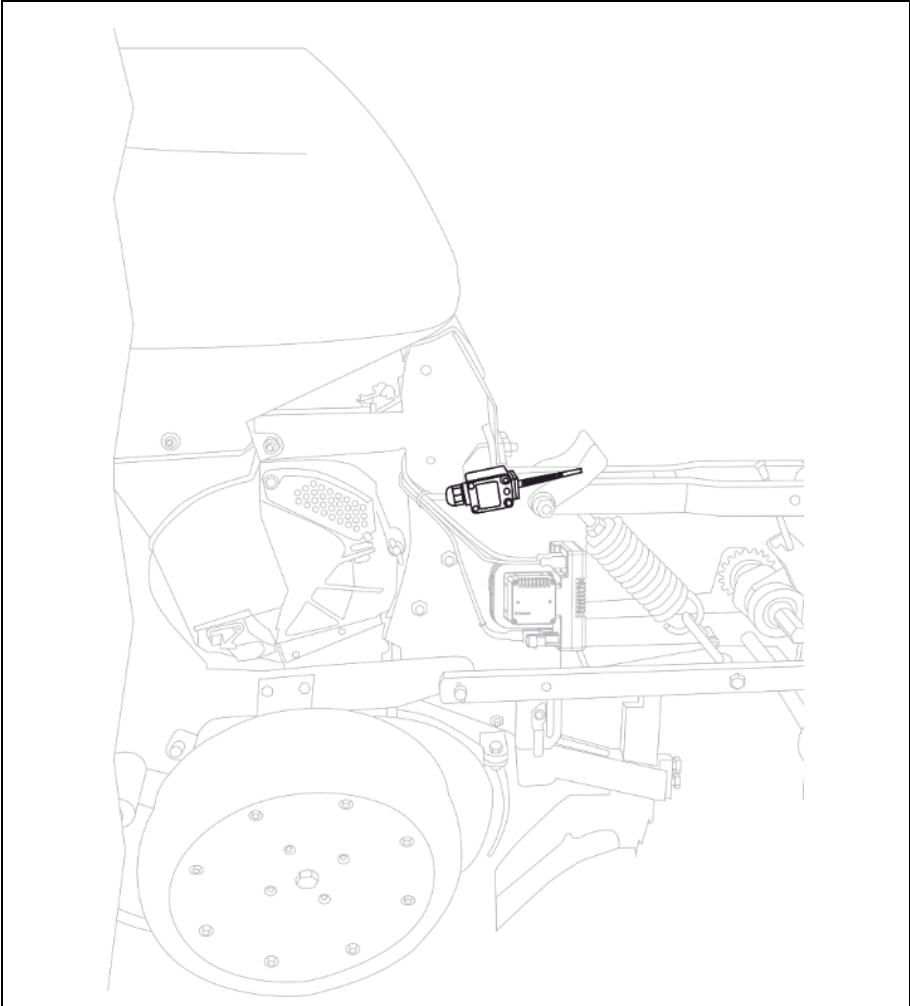



Figure 2 - Work sensor installation

	<p>Warning The sensor cable should be protected with a rubber sheath.</p>
---	--

3.3 Photocells installation and wiring

The photocells must be positioned on every single row of the planter so that when the seed falls, it passes through the two photocell elements.

To install the wiring harness proceed as follows:

- distribute the wiring harness cables fastening them to the planter's air pipes with clamps, paying attention to the numbers on the cables near the connectors: cable no. 1 corresponds to row no. 1 of the Monitor, cable no. 2 corresponds to row no. 2 of the Monitor, etc... It is important to consider the planter's first row (starting from either right or left) as "no. 1 row" and that the other be connected in sequence: Figure 3 shows an example of a six-row wiring harness application taking the first row on the left of the planter, as reference;
- position the junction box **(A)** at the centre of the planter, fastening it with clamps;

To install the photocells proceed as follows:

- If the sowing elements of the planter are "high" and come with seeding pipes, that bring seeds to the ground, you should install photocells for pipe, and should be installed at about half the length of the pipe (Figure 4).
- If the sowing elements of the planter are "low" and the seeds fall directly from the disc to the ground, you should install photocells with bracket (according to the type of planter), and should be assembled directly onto the sowing element (Figure 5).



Warning

Make sure that photocells do not interfere with the dropping seeds, or the moving mechanical parts of the sowing element.

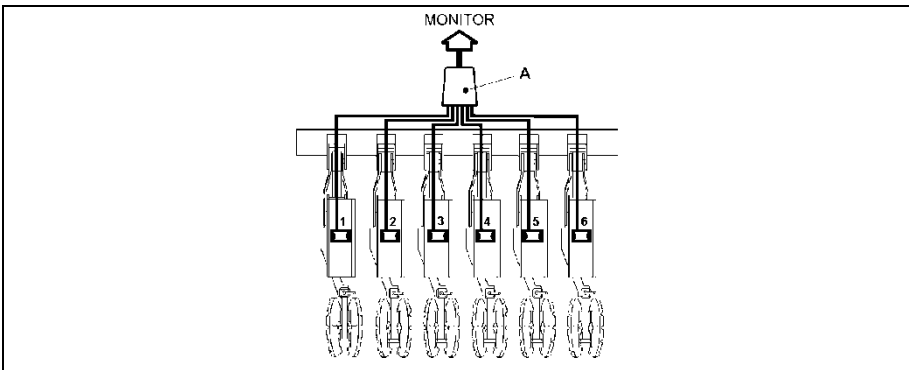

Figure 3. Wiring harness installation.

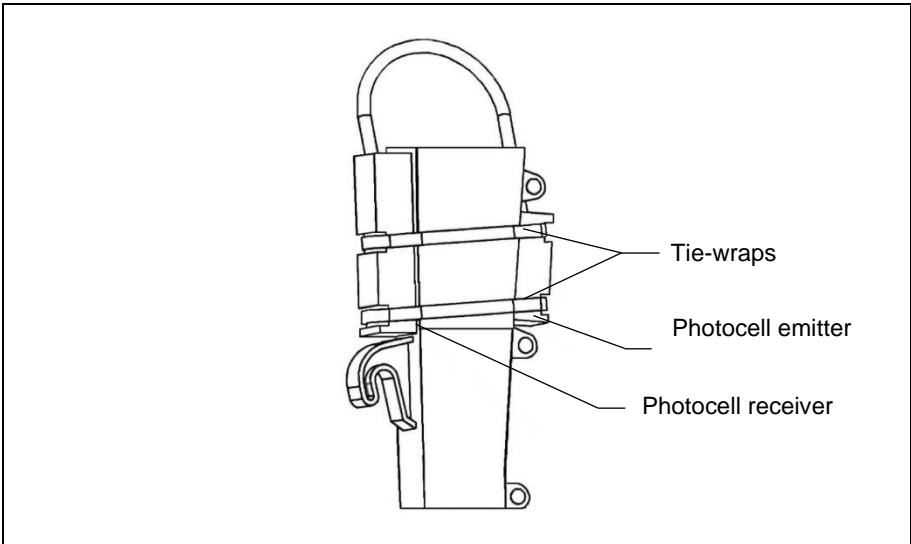

Figure 4. Example of photocell installation on seed pipe.

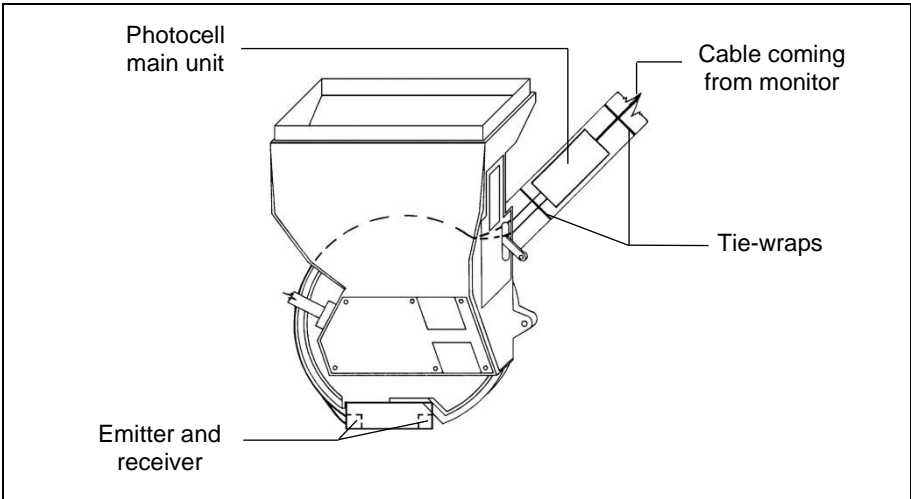

Figure 5. Example of installation of a photocell with bracket on the sowing element.

3.4 Flowmeter installation (optional)

The flowmeter sensor could be used if you wish to check the simultaneous distribution of weed killer while monitoring the seeding.

Place the flowmeter sensor **(A)** as indicated in Figure 6, so that all the weed killer passing through the flowmeter is then actually distributed, since there must be no discharges or returns of weed killer into the tank after the flowmeter.

Note: Figure 6 shows the flowmeter p/n 952, but the installation principle is the same as for p/n 598

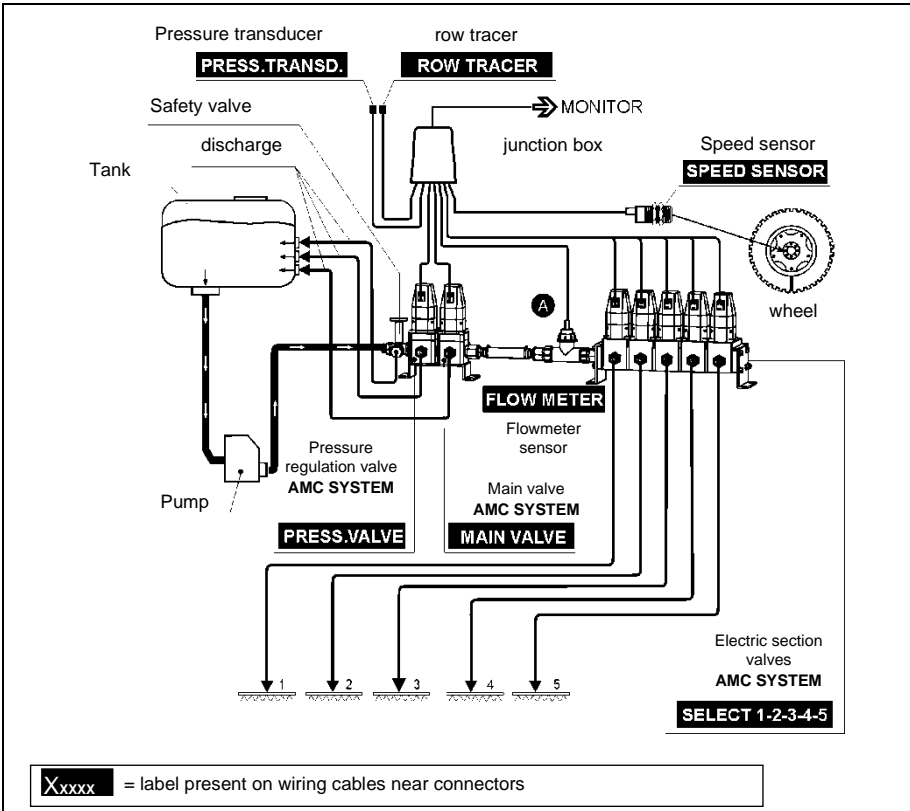

Figure 6. Installation principle of flowmeter sensor

3.5 Fan speed sensor installation (optional)

An inductive sensor could be used, to detect the speed of fan of planter. It should be positioned in front of metal bolts, with a diameter at least equal to the sensor's head, and protruding from the backplate at least 7mm. The distance between the sensor and the bolts can vary between 2 to 3mm.

The figures below show two different installation examples.

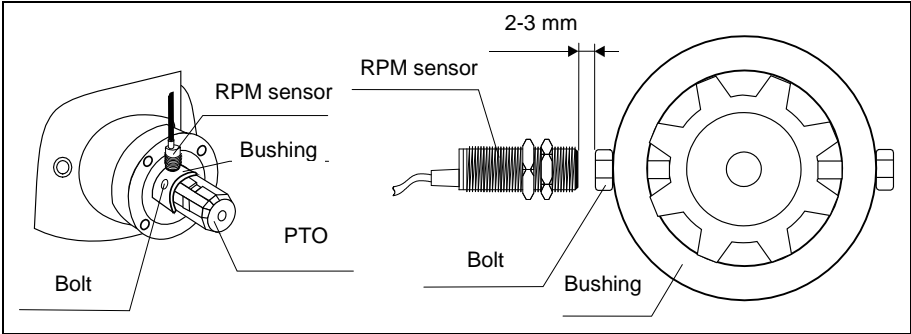

Figure 7. Installation of the inductive sensor D.18 on the PTO.

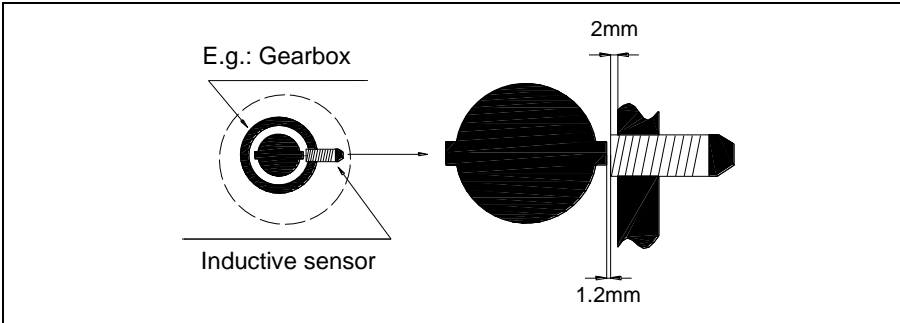

Figure 8. Installation of the inductive sensor D.12 on the gearbox.

	<p>Warning The sensor cable should be protected with a rubber sheath.</p>
--	--

4. Operation

4.1 Splash screen



Figure 9.

The splash screen is displayed immediately after switching on. It shows the logo of the product, system name and currently installed SW version. After a few seconds, this screen disappears and the main screen is shown.

4.2 Main screen

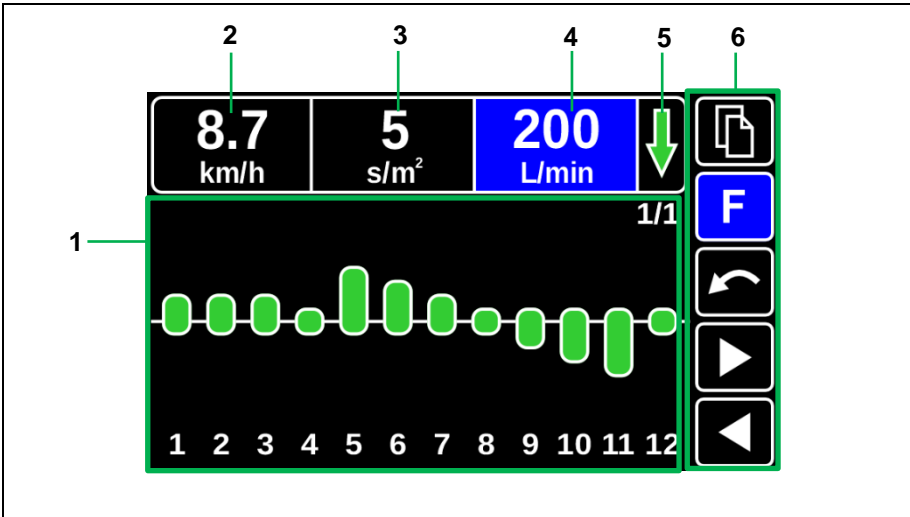



Figure 10.

The main screen allows the user to see at a glance all the info about the seeding operation. In detail, these are the elements of this screen:

- Seeding quality:** display of the seeding status of each individual row represented by histograms.
If an error condition is detected, it's displayed above the histograms, with a red flashing box: when pressed, it displays the list of active alarms. 





Furthermore, by pressing the histogram area it is possible to change the display mode from graphic to tabular form.

- Vehicle speed:** displays real-time ground speed.
With simulated speed active, the background of this area turns orange.
If pressed, it allows direct access to the "speed sensor" menu.
- Sowing distance & Population:** depending on the configuration, it is possible to monitor the average value of the sowing distance or the population value of all rows. If this area is pressed, it is possible to access the seeding menu.
- Multi-function area:** the blue area at the right shows many different values, that can be selected with the blue multifunction soft-key "F" at far right.

The parameters that can be shown are:

- vacuum level of the seeding unit (-mBar) or inches mercury (inHg)
 - rev speed of fan or PTO (RPM)
 - weed killer dose distributed per minute (litres/min)
 - weed killer dose distributed per hectare (litres/ha) or gallons per acre (gal/ac)
 - counter of litres of weed killer distributed (litres)
 - partial area worked in hectares (ha) or acres (ac)
 - partial counter working time (h)
 - linear distance covered in metres (m) or feet (ft)
 - Instantaneous productivity (ha/h) or acres per hour (ac/h)
- If pressed for more than 3 seconds, it resets the displayed parameter to zero.

5. **Work status:** the downward arrow is shown when the planter is lowered in its working position. The icon pointing up instead shows when the planter is lifted for road transport.
If the manual working mode is active, the down arrow is displayed with an orange background.
By pressing this area, it is possible to access the working sensor menu.
6. **Touch softkeys:** in this area there are touch keys for managing the main screen.

Icon	Softkey function
	Menu: accesses to system menu
	Multi function: changes the parameter displayed in the blue box of the main screen
	Backwards: cancels an active function (e.g. simulated speed and work)
	Next page: shows the next group of photocells on the main screen, if there are more than 12
	Previous page: show the previous group of photocells on the main screen, if there are more than 12

4.2.1 Seeding quality area

If the working mode parameter is set to "counting", the population and sowing distance of each row can be measured from the photocells statistics. The user can choose between three different layouts of this area: histograms, table of sowing distance, or table of populations.

By touching the central area, it is possible to scroll between its different layouts.

- (1) **Histograms:** the sowing statistics of each row are graphically represented by histograms:



- (2) **Sowing distance table:** the sowing distances of each row are displayed numerically on a table:





cm		ALARM !		1/4			
1	19.1	2	19.1	3	10.1	4	19.1
5	19.1	6	10.1	7	19.1	8	19.1
9	19.1	10	!	11	--	12	19.1



- (3) **Seeding population table:** the seeding population of each row is displayed numerically on a table:

s/m2		ALARM !		1/4			
1	8.1	2	8.1	3	12.1	4	8.1
5	8.1	6	12.1	7	8.1	8	8.1
9	8.1	10	!	11	--	12	8.1

4.2.1.1 Histograms



Each histogram represents a seeding row. The height of each histogram is updated in real time, proportionally to the sowing distance of that row:

Histogram	Description
	<p>Under seed: the seeding distance is higher than the target value (or population is too low). The histogram is red and displayed above the centre line with the maximum height.</p>
	<p>Over seed: seeding distance is lower than target value (or population is too high). The histogram is red and displayed below the centre line, with the minimum height.</p>
	<p>Seeding distance within upper limit: histogram is green and displayed above the centre line, with its height proportional to difference between seeding distance and target value.</p>
	<p>Seeding distance within lower limit: histogram is green and displayed below the centre line, with its height proportional to difference between seeding distance and target value.</p>

	<p>Seeding distance on target: when seeding distance is on target, a small green histogram is shown at the center line.</p>
	<p>Alarm: If an error occurs on a row, a yellow warning icon appears in front of the histogram. The colour of the histogram can vary according to the severity of the problem:</p> <ul style="list-style-type: none"> - Red: Block or fault alarm - Orange: Warning - Blue: info



4.2.1.2 Tables display

The system allows you to view the values of sowing distance and seeding population on two different tables. To access the table display, just press any point in the histogram area.

Up to 12 rows can be displayed at a time. If the system has of more than 12 rows, you can scroll to other pages with these buttons  .



For the sowing distance table, the unit of measurement printed at the top left can be in **cm** or **in**, depending on the measurement system. The seeding population table is displayed in **seed/m²** or **seed/ft²**.

In detail, if the system is set to **counting mode**, the tables could show:

Box	Description
	<p>Over seed: seeding distance is lower than target, or population is higher than target. The background goes red.</p>
	<p>Under seed: seeding distance is higher than target, or population is lower than target. The background goes red.</p>
	<p>Sowing within limits: seeding distance and population are within the programmed tolerances of target values.</p>

	<p>Alarm: In case of an active alarm on a row, the background colour can be:</p> <ul style="list-style-type: none"> - Red with warning icon: blockage or fault alarm - Orange: warning - Blue: info
---	--

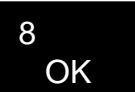
While in **passage mode**, the tables can show:

Box	Description
	<p>OK: The photocell is detecting seeds and has no active alarm. The box shows a fixed 'OK' label with a black background.</p>
	<p>Alarm: In the event of an active alarm on a photocell, the background colour could be:</p> <ul style="list-style-type: none"> - Red with warning icon: blockage or fault alarm - Red with "ERR" label: no seeds detected - Orange with "OK" label: warning, with seeds detected - Blue with "OK" label: info, with seeds detected

4.3 Menu

To enter the programming menu, press the menu key until the first page appears:

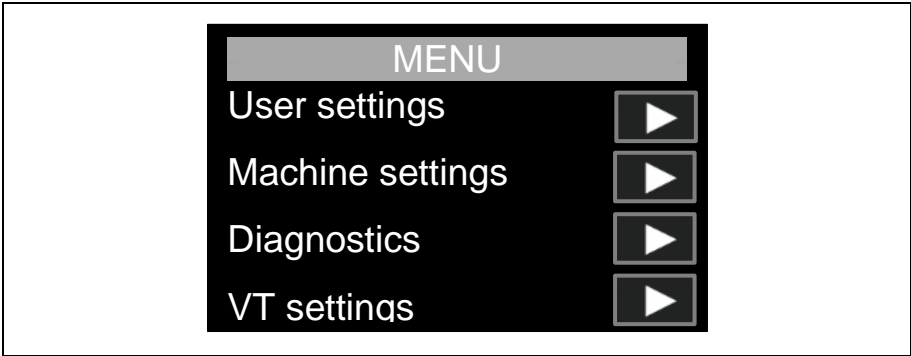





Figure 11.

In general, the user can select a parameter he wants to modify in any menu, by touching its name or value. When a parameter is selected, it's value background turns GREY.

In case of numeric parameters, the digits shall be edited one at a time with the softkeys shown below: the selected digit is highlighted in red.

In case instead of a parameter with a dropdown list, scroll and select the available settings.

Icon	Softkey function
	ESC: cancels the modification and restores the previous value
	PLUS: increments the selected digit or scrolls to next item in dropdown lists
	MINUS: decreases the selected digit or scrolls to previous item in dropdown lists
	ENTER: confirms the entered digit and select the next one, or confirms the item in a dropdown list.

4.3.1 User settings

This submenu allows you to adjust the main working parameters:

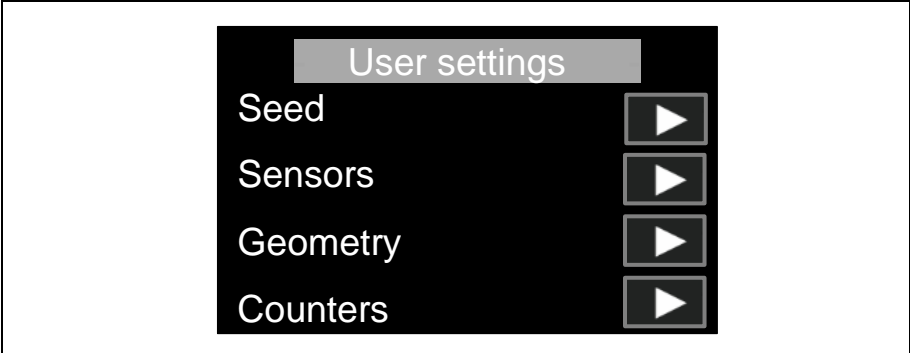

Figure 12.

4.3.1.1 Seed menu

The seed menu allows you to set the desired seeding mode and parameters:

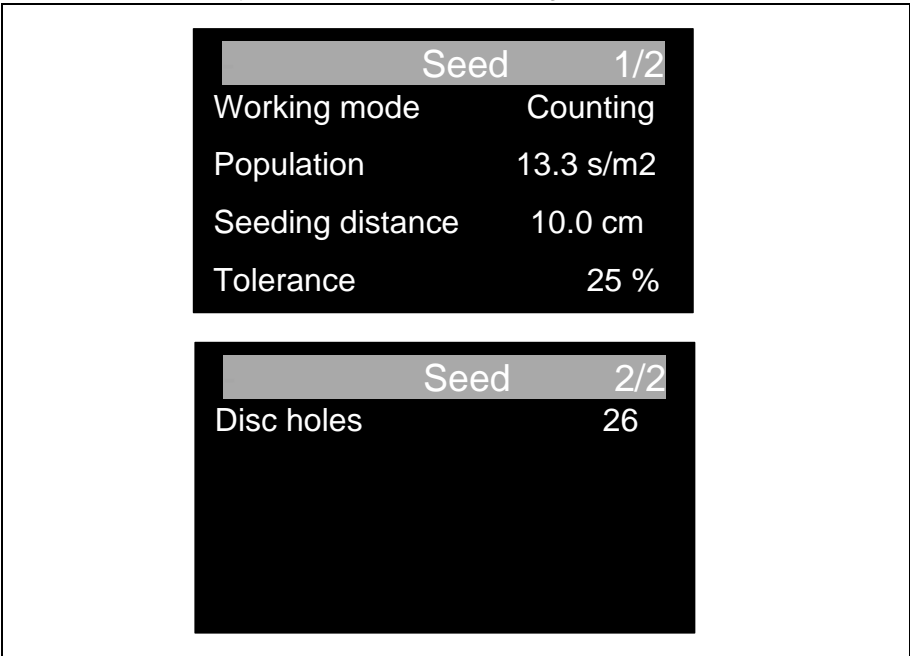

Figure 13.

- **Working mode:** allows you to set the mode for calculating and verifying the sowing distance and population. The DORADO EVO system allows the user to choose between two modes:
 - **Counting:** measures sowing distance and population from photocells of each row, and compares their value vs. target. For most accurate reading, generally use this setting;
 - **Passage:** checks only presence or absence of pulses from photocells of each row, without measuring any distance or population. Use this setting, if the photocells are not capable of accurately detect the type of crop used.
- **Population:** in counting mode, sets the target seeding population, for computing histograms and tables.
This value is linked to seeding distance target: if you change one, the other is refreshed automatically.
- **Seeding distance:** in counting mode, sets the target seeding distance, for computing histograms and tables.
- This value is linked to population target: if you change one, the other is refreshed automatically.
- **Tolerance:** sets the % range of tolerance for population and seeding distance, above which alarms are triggered.
- **Disc holes:** sets the number of holes of the seeding disc, to accurately compute the seeding distance from photocell's pulses.

4.3.1.2 Sensor menu

This submenu allows you to adjust the sensors connected to the system:

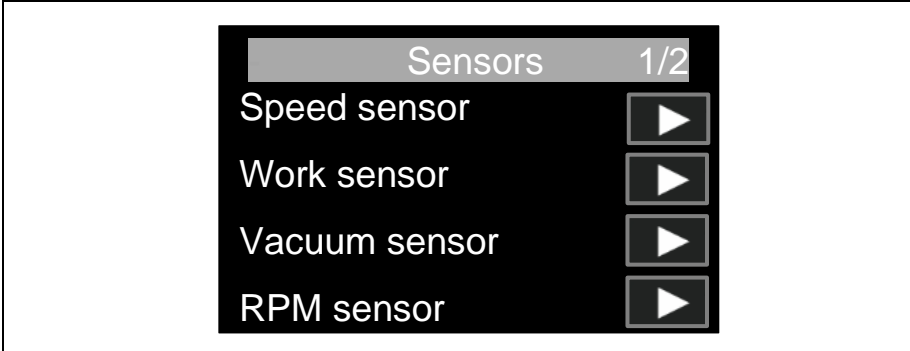

Figure 14.

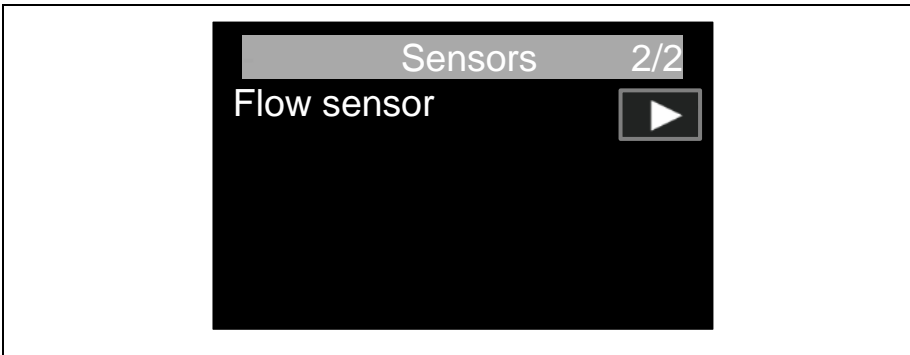

Figure 15.

4.3.1.2.1 Speed sensor

This submenu allows you to adjust the parameters of speed sensor:

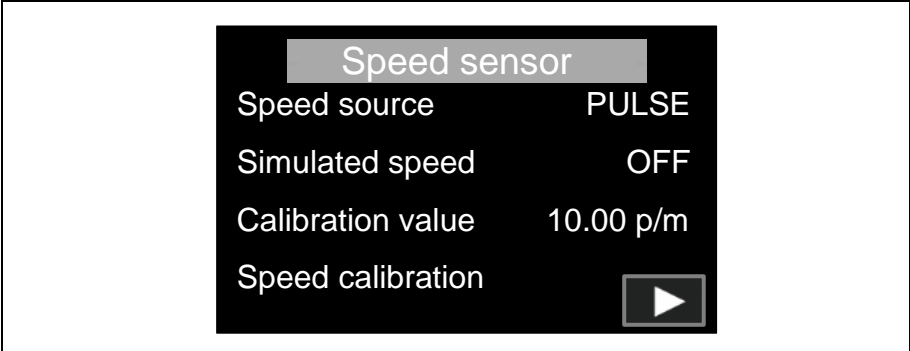
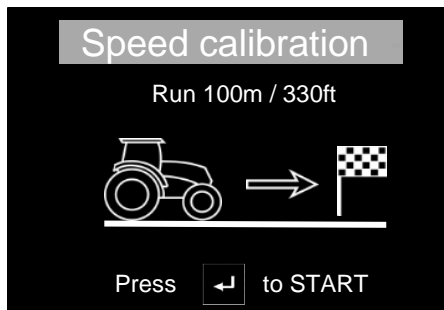

Figure 16.

- **Speed Source:** selects the source of vehicle speed reading:
 - PULSE: read the speed from the input present on this device;
 - J1939: reads the speed from the CAN BUS network;
 - NMEA: reads the speed from the RS232 network.
- **Simulated speed:** When this parameter is OFF, the systems reads the vehicle speed from the programmed source. When ON, a speed value is forced ignoring any other source. In the main screen, the speed value is highlighted with orange background. Furthermore, by pressing the CANCEL softkey in the main screen, the simulated speed is disabled and the programmed speed source is restored.
- **Calibration value:** sets the number of pulses generated by the pulse speed sensor per meter.
- **Speed calibration:** through this submenu it is possible to carry out the automatic calibration procedure.



To perform the automatic calibration, the following steps should be followed:

1. Place two markers on the ground 100 metres apart.
2. Move the tractor to the first marker, and press the ENTER key to start the procedure.

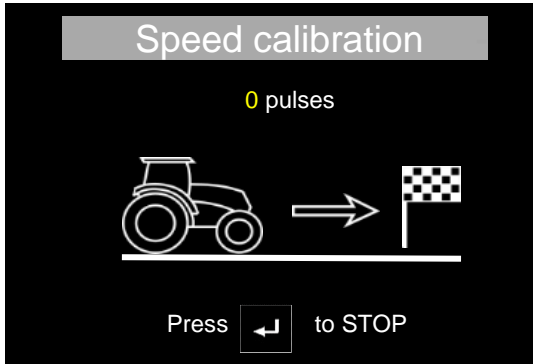

3. Drive the tractor to the second marker and press ENTER again to stop the procedure. While the tractor is moving, the system accumulates the pulses generated by the speed sensor;
4. If procedure ends without errors, the the pulses accumulated over 100 meters are shown, and the calibration value of speed sensor is automatically computed.

NOTE: if the number of pulses acquired during the procedure are not enough, an error warning will be displayed and the procedure is cancelled, and should be repeated after checking the installation of the speed sensor.

4.3.1.2.2 Work sensor

This submenu allows you to adjust the parameters of work sensor:

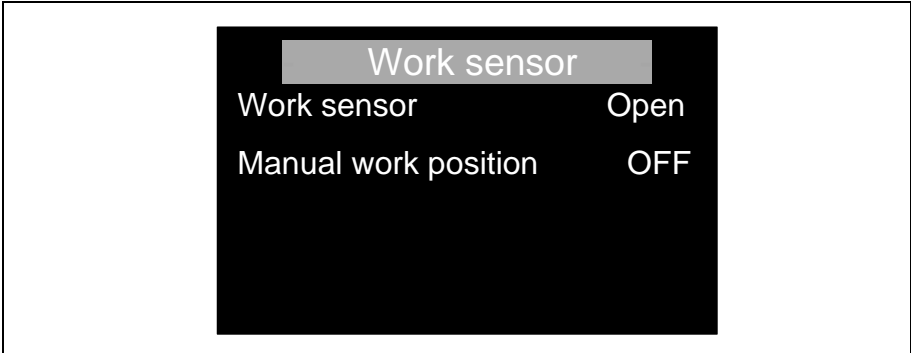

Figure 17.

- **Work sensor:** the parameter defines whether the working position corresponds to the open or closed contact of the sensor
- **Manual work position:** When manual work is ON, the system ignores the reading of physical work sensor, and forces a set state. The work icon on the main screen is highlighted orange to alert the user about this simulated condition.
On the main screen, this simulated condition can be cleared by pressing the CANCEL softkey, thus disabling the manual mode and turning back to physical sensor.

4.3.1.2.3 Vacuum sensor

This submenu allows you to adjust the parameters of optional vacuum sensor:

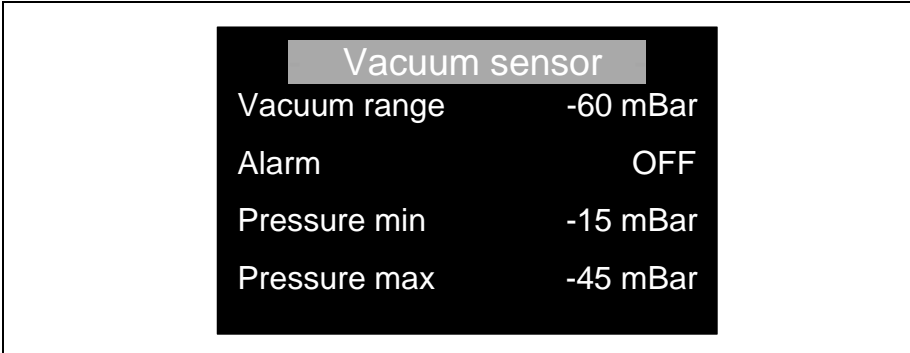

Figure 18.

- **Vacuum range:** defines the full scale of the vacuum gauge sensor.
- **Alarm:** allows you to activate or deactivate the alarm according to the pressure limits entered below.
- **Pressure min:** defines the minimum pressure threshold for activating the alarm status.
- **Pressure max:** defines the maximum pressure threshold for activating the alarm status.

4.3.1.2.4 RPM sensor

This submenu allows you to adjust the parameters of optional RPM sensor (for fan or PTO):

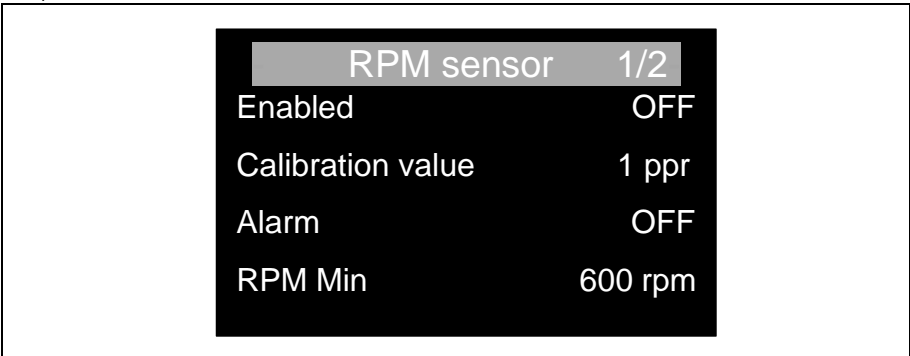

Figure 19.

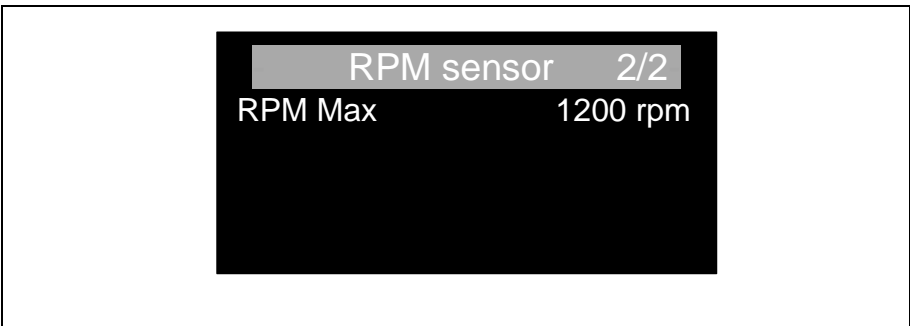

Figure 20.

- **Enabled:** activation or deactivation of optional sensor.
- **Calibration value:** sets the number of pulses per revolution detected by the sensor.
- **Alarm:** allows you to activate or deactivate the alarm according to the limits entered below.
- **RPM Min:** defines the minimum RPM alarm threshold (if enabled).
- **RPM Max:** programming of the maximum threshold above which the RPM alarm is triggered (if enabled).

RPM sensor and flow sensor cannot be used at the same time, since they share the same physical input. Therefore, you can't enable both together.

4.3.1.2.5 Flow sensor

This submenu allows you to adjust the parameters related to the flow sensor:

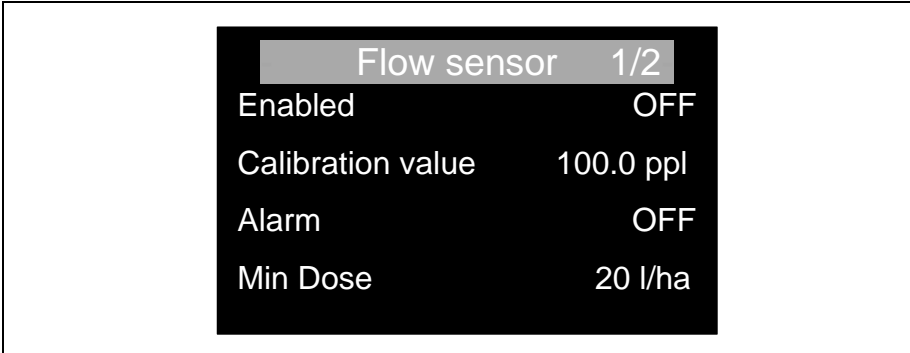

Figure 21.

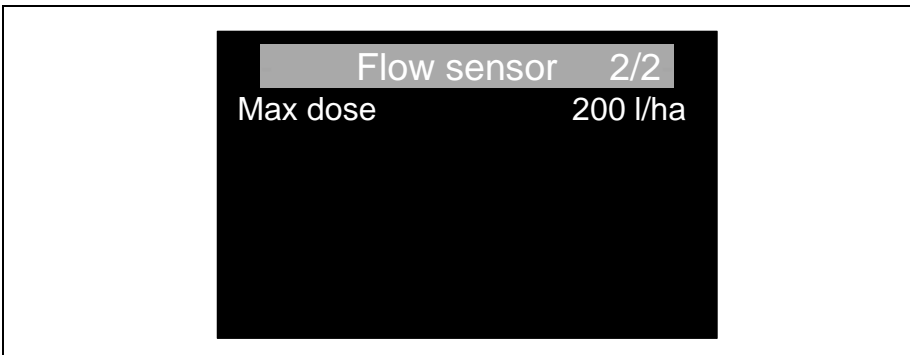

Figure 22.

- **Enabled:** activation/deactivation of the optional flow sensor.
- **Calibration value:** sets the number of pulses per liter detected by the sensor.
- **Alarm:** allows you to activate or deactivate the alarm according to the set dose limits.
- **Min Dose:** defines the minimum alarm threshold of the flow sensor (if enabled).
- **Max Dose:** defines the maximum alarm threshold of the flow sensor (if enabled).

RPM sensor and flow sensor cannot be used at the same time, since they share the same physical input. Therefore, you can't enable both together.

4.3.1.3 Geometry

This menu allows you to configure the mechanical characteristics of the planter:

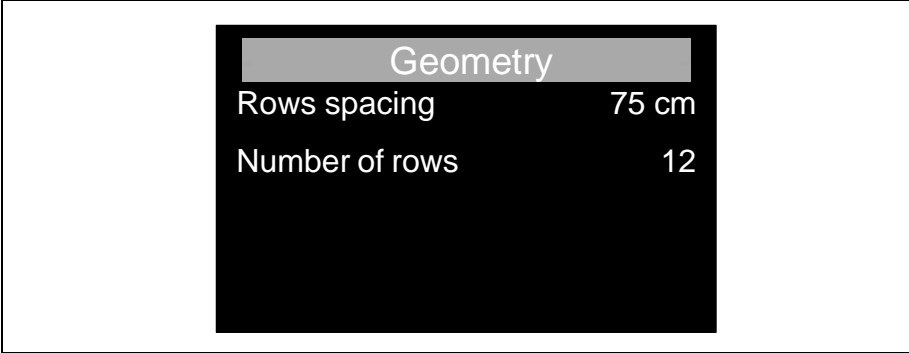

Figure 23.

- **Rows spacing:** sets the distance between the rows.
- **Number of rows:** number of rows of the planter.

4.3.1.4 Counters

This menu allows you to view all the counters available in this system.

Up to 10 sets of independent partial counters are available, each one assignable to a different customer.

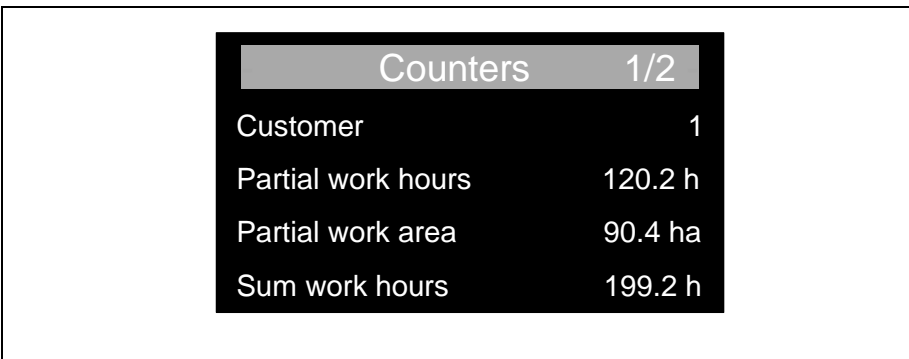

Figure 24.

Counters		2/2
Sum work area	199.4	ha
Total work hours	1220.2	h
Total work area	890.4	ha
Odometer	5499.6	m

Figure 25.



- **Customer:** select the set of counters for different customers, from 1 to 10.
- **Partial work hours:** partial worked time of selected customer. When reset, its previous value is added into the sum work hours of same customer.
- **Partial work area:** partial worked surface of selected customer (e.g. a field). When reset, its previous value is added into the sum work area of same customer.
- **Sum work hours:** sum of partial worked hours of selected customer, since last reset. When reset, the value is added into total work hours of same customer.
- **Sum work area:** sum of partial worked areas of different fields of selected customer, since last reset. When reset, the value is added into total work area of same customer.
- **Total work hours:** total seasonal worked time of selected customer, since last reset.
- **Total work area:** total seasonal worked area of selected customer, since last reset.
- **Odometer:** overall odometer of the planter, regardless of selected customer. This counter is not resettable

Note: the total time and area counters of planter are shown inside Machine Settings menu. Those cannot be reset.

The user can reset the partial, sum and total counters of the selected customer by simply touching the desired counter line. Before resetting, a confirmation window is displayed:



Figure 26.

Icon	Function
	ESC: cancels the reset, and keeps the counter value
	Confirm: confirms the reset and clears the selected counter to zero

4.3.2 Machine settings

The Machine settings is a password-protected menu, reserved to authorised personnel for changing core parameters.

The user shall enter a 4-digit numeric password, one digit at a time: if correct, it allows entering into the submenu, otherwise a 'Wrong password' warning message appears.

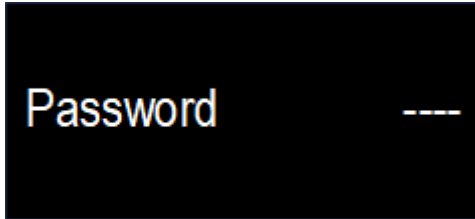

Depending on the password entered, it is possible to access a first level reserved for service engineers with limited functionality; or a second level for development engineers.

With the service access level, all parameters are visible, but some cannot be changed. After entering the right password, this menu appears:

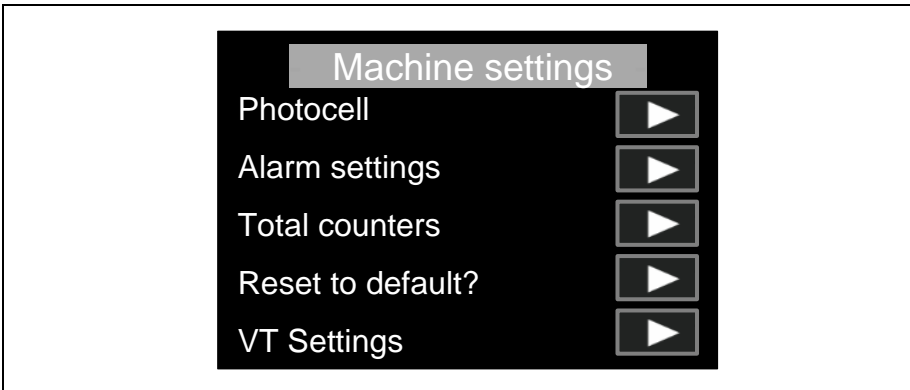

Figure 27.

4.3.2.1 Photocell

In this submenu the service technician can manage the photocells of the system:

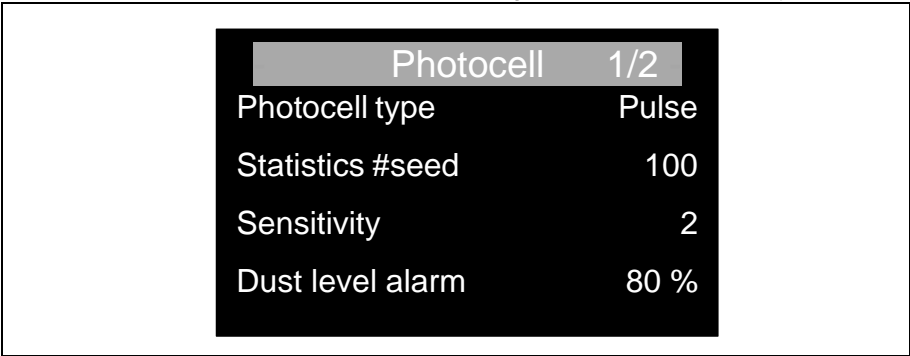

Figure 28.

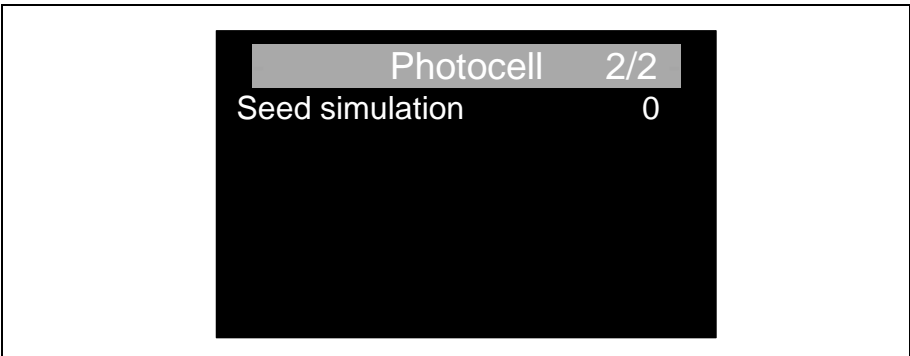

Figure 29.

- **Photocell type:** sets the type of photocell connected.
- **Statistic # seed:** value relating to the number of seeds used to calculate sowing statistics.
- **Sensitivity:** defines the sensitivity of the photocell according to the seed used. When the photocell type is set as impulsive, this parameter is not taken into account by the system.
- **Dust level alarm:** allows you to set the dust level at which the dirty photocell alarm is triggered.
- **Seed simulation:** this parameter can be used to activate a simulated seeding frequency. When this value is at zero, the seeding simulation is disabled.

4.3.2.2 Alarm settings

This submenu allows you to fine-tune the system's alarms:

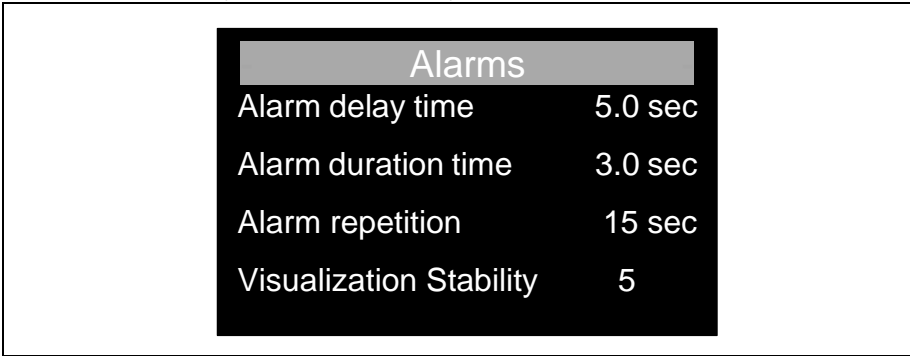

Figure 30.

- **Alarm delay time:** sets the waiting time between the detection of a fault condition and the triggering of the relevant alarm.
- **Alarm duration time:** defines the maximum duration of an active alarm, after which it's automatically snoozed. Alarms that remain active after snoozing can be listed by pressing the alarm icon on main screen.
- **Alarm repetition:** if an alarm is still active after snoozing, it will be respawned after this delay.
- **Visualization Stability:** when in counting mode (see Seed menu), this parameter adjusts the refresh rate of histograms on main screen.

4.3.2.3 Total counters

This submenu shows the life-time total counters of the planter:

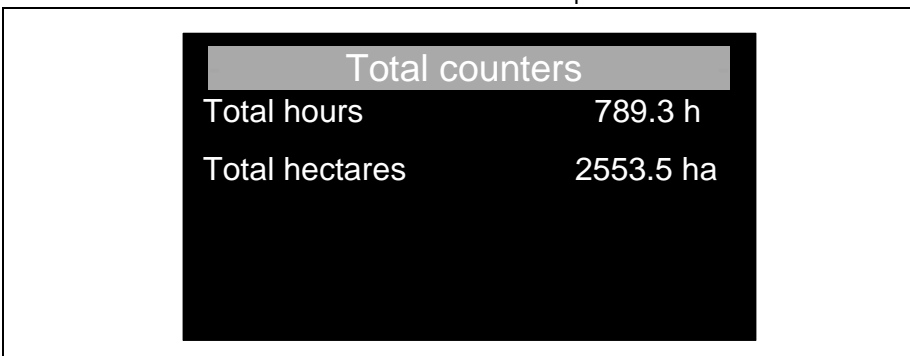

Figure 31.

- **Total hours:** total worked hours of the planter (non-resettable).
- **Total hectares:** total worked area of the planter (not resettable).

4.3.2.4 Reset to default ?

Should you need to restore the system to its initial, factory configuration, you can use this function. Before the reset is performed, a confirmation screen appears, as below:



Figure 32.

If confirmed, the system resets all parameters to the factory default values.

4.3.3 Diagnostics menu

Through this submenu, system diagnostic information can be displayed:

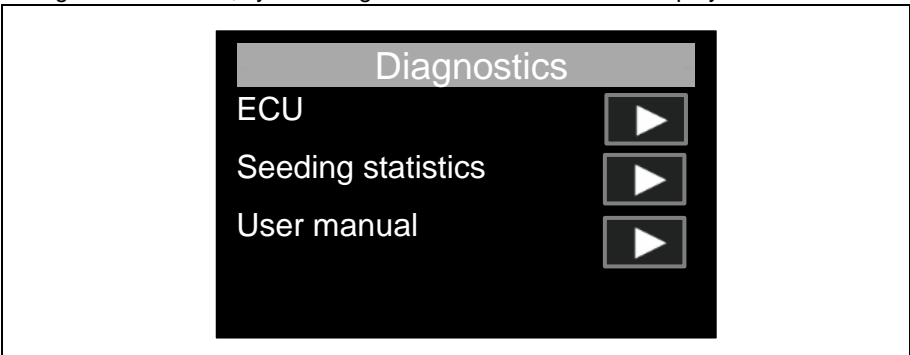

Figure 33.

- **ECU:** displays diagnostic info of this product;

- **Seeding statistics:** allows you to check the seeding statistics of each row;
- **User manual:** displays a QR link to this on-line manual.

4.3.3.1 ECU

This screen lists all diagnostic information for this product:

ECU 1/4	
Power supply IN	12.2 V
Power supply OUT	12.4 V
Firmware	1.1.0
Bootloader	1.0.0

Figure 34.

ECU 2/4	
Info Warning Table	0X0
Lock warning table	0X0
Primary communication	OK
Secondary communication	OK

Figure 35.

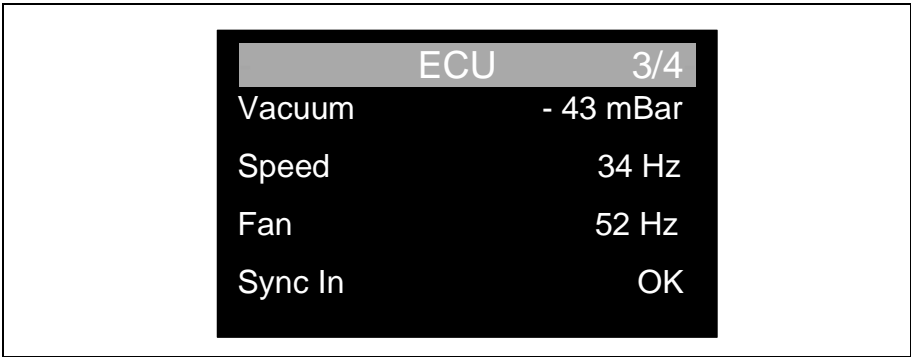

Figure 36.

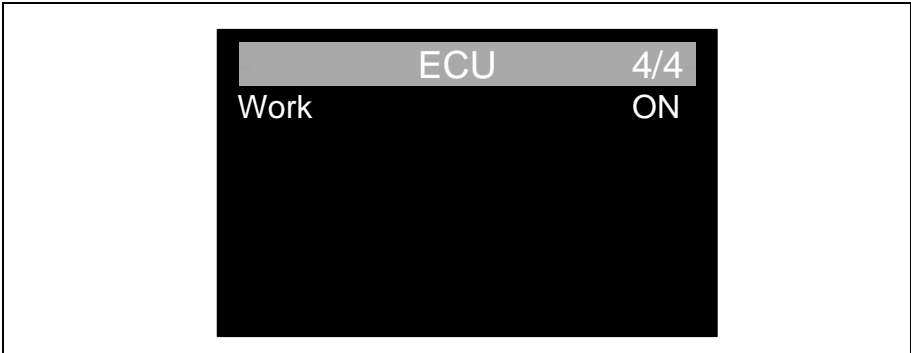

Figure 37.

- **Power supply IN:** input power supply voltage to the monitor.
- **Power supply OUT:** power supply voltage output to the sensors.
- **Firmware:** firmware version in use.
- **Bootloader:** bootloader version in use.
- **Info warning table:** cumulative value of active information alerts.
- **Lock warning table:** cumulative value of active block alarms.
- **Primary communication:** CAN BUS communication status of the display.
- **Secondary communication:** LIN BUS communication status of the display.
- **Vacuum:** vacuum gauge sensor value.
- **Speed:** frequency read by the speed sensor.
- **Fan:** frequency read by the fan sensor.
- **Sync In:** status of the Sync In input.
- **Work:** work sensor input status.

4.3.3.2 Seeding statistics

This submenu shows the seeding statistics of each photocell. The user can select the photocell he wants to check with the appropriate softkeys. The number of the currently selected photocell is displayed in the upper right corner of the screen, followed by the total number of photocells installed (e.g. 4/12).

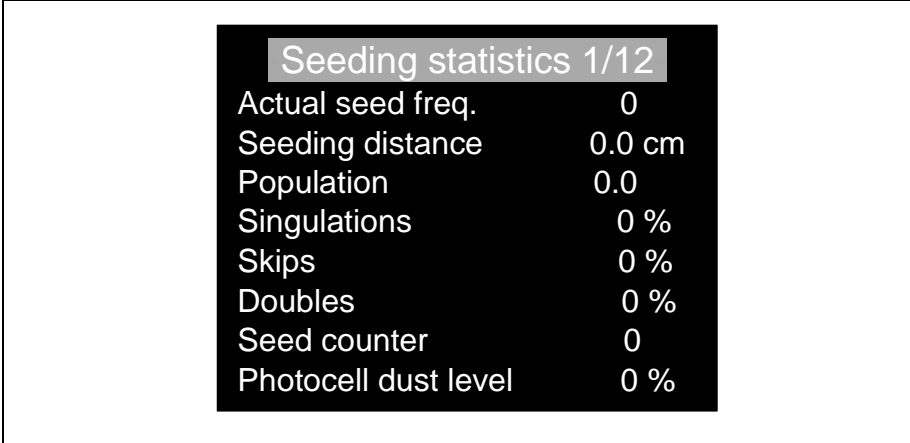

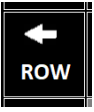
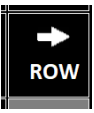



Figure 38.

- **Actual seed freq.:** frequency of detected seeds.
- **Seeding distance:** calculated value of the actually detected seeding distance.
- **Population:** calculated value of actually detected seed population.
- **Singulations:** % of single seeds detected compared to expected.
- **Skips:** % of undetected seeds compared to expected.
- **Doubles:** % of multiple seeds compared to expected.
- **Seed counter:** number of seeds counted from the beginning of the working section.
- **Photocell dust level:** % of dust detected by selected photocell.

Icon	Softkey function
	Main screen: allows you to return to the main screen
	ESC: allows you to go back one level

	Previous row: shows the previous row statistics
	Next row: shows the next row statistics
	Reset seed: if pressed, it resets all the statistical data of the currently selected photocell. No confirmation is required.

4.3.3.3 User manual

This page displays a QR link to this manual on-line:



Figure 39.

4.3.4 VT settings

This screen shows the settings of the display:

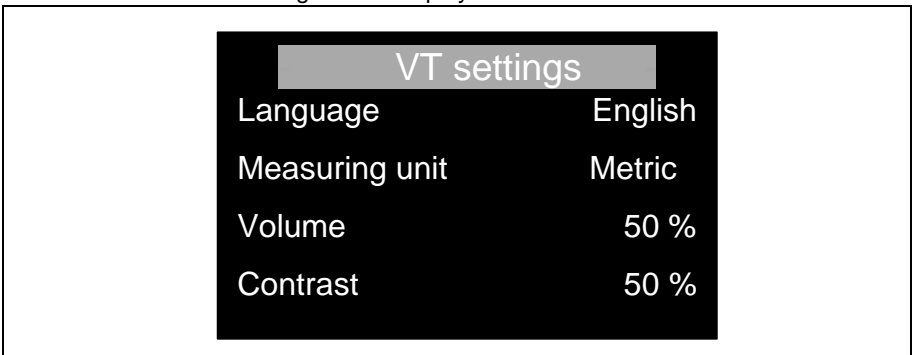
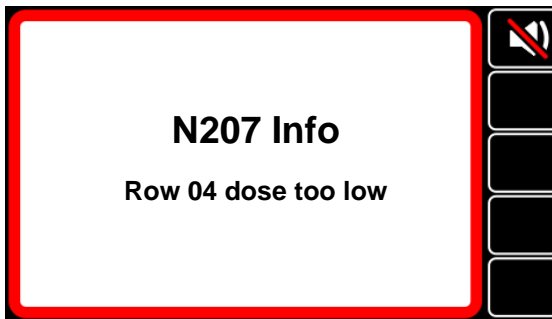

Figure 40.

- **Language:** select the desired language.
- **Measuring unit:** select Metric or Imperial measurement system.
- **Volume:** sets the volume of integrated the buzzer alarm.
- **Contrast:** sets the display contrast.

4.4 Alarms

This product implements real-time alarm management for all system components, i.e. sensors, photocells and the display itself. If an alarm condition is detected, an alarm window is immediately popped-up on screen:



If several alarms are active at the same time, the relative alarm windows are displayed one by one, in order of group and priority; once the highest priority alarm is silenced, the next one should be displayed, and so on.

In general, alarm show a line of text with alarm ID and type, then a brief description. While the alarm window is visible, a repeated “beep” sounds from internal buzzer, until the alarm is snoozed or the programmed alarm duration time expires.

When there is at least one active alarm, even if snoozed, the "ALARM" reminder box appears in the main screen.

Therefore, if the user wants to check the active alarms, simply press the "ALARM" reminder button on the main screen to view the list of all active alarms, sorted by group (block, fault, error, warning, info) and priority:

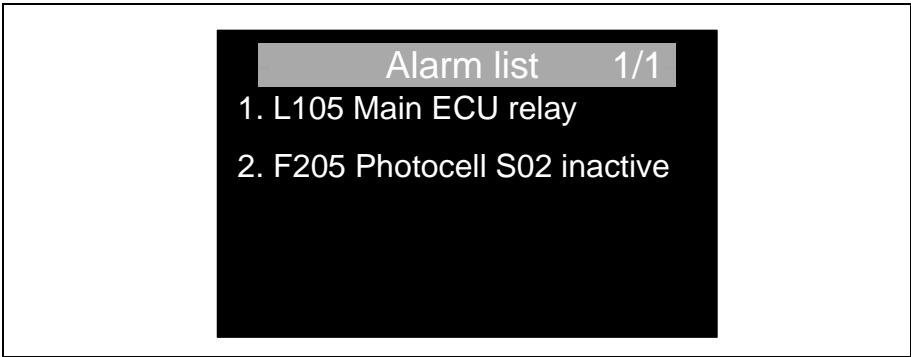

Figure 41.

4.5 Update

The system can be updated by connecting a USB mass storage device.

Here are the steps to follow:

1. Prepare the USB pen drive with a valid update file;
2. Connect the pen drive into the back of the monitor;
3. Wait for a pop-up window to appear:

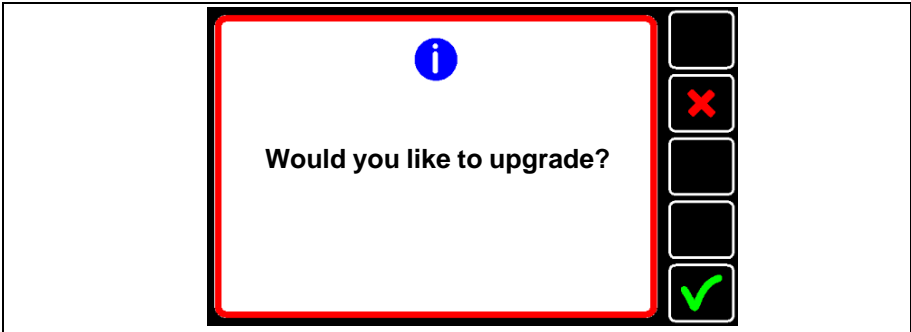



Figure 42.

4. Press the button  to confirm the update
5. Wait for the process to load:

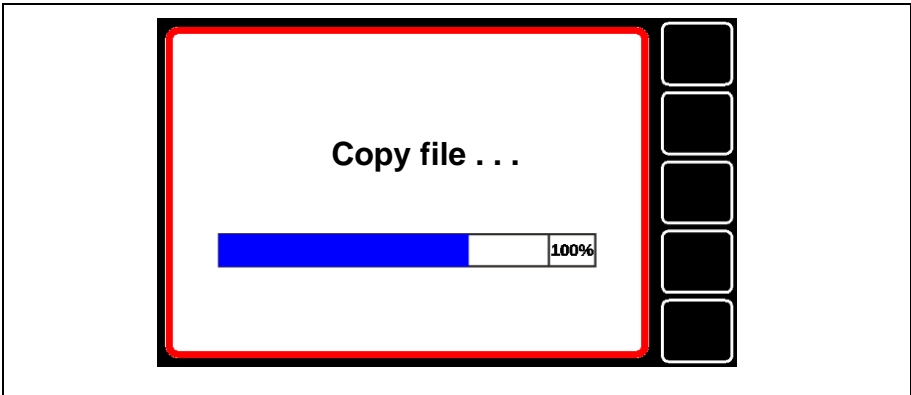

Figure 43.

6. After loading is complete, restart the device.

The following error message may be displayed for any errors during the update.

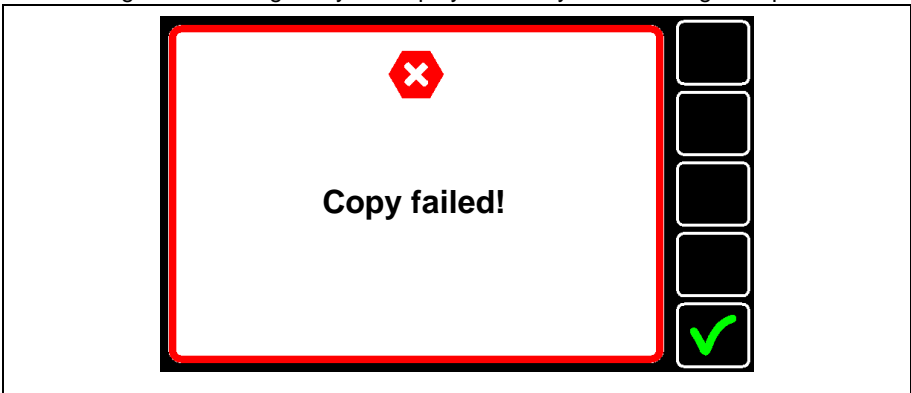

Figure 44.

CAUTION!!
DO NOT USE PRESSURE JET WASHING



WARNING: THIS PRODUCT CONTAINS TIN, AT THE END OF THE LIFE CYCLE MUST BE DISPOSED OF IN APPROPRIATE COLLECTION AREAS, OR RETURNED TO MC ELETTRONICA FOR RECYCLING (ITALY)



Smart farming solutions

www.mcelettronica.it